



Duro 4.5 Corner Wrap Applicator

Description

The Duro 4.5 Labeler is perfect for labeling boxes that require the label to wrap around the corner edge. It comes with our standard Duro 4.5 Labeling Head that is capable of speeds up to 1000 inches per minute. It will apply labels up to 4 ½" tall and up to 14" in length. An optional 6" high web is also available.

Label gaps are detected by a through-beam photoeye and product detection is by photoelectric eye.

With the Corner Wrap Applicator, the leading edge of the container is detected by the first of two photo eyes. An adjustable time delay will allow a label to be dispensed onto the side of the container as it passes the web. A stationary brush wipes down the first half of the label leaving the second half flagged behind the back edge of the case. A second photo eye detects the trailing edge of the container, and as it disappears from its sensory range, a pneumatic

brush fires out and wipes down the second half of the label across the back of the container.

The conveyor belt that typically comes with this machine can reach speeds up to 600 inches per minute. We have other options available that take into consideration the speed and length required for your specific application.



Duro 4.5 Corner Pneumatic Wiper Brush

Features

- Apply labels from 1" to 4 ½" tall and 14" long.
- Accommodates conveyor speeds up to 600 ipm with a maximum rate of 60 labels per minute.
- Recognizes ⅛" standard to ¼" label gap.
- Accepts 12" label roll and industry standard 3" diameter core.
- Photoeye product detection and photoeye gap detection.



Specification

- Hot Stamp coding for lot/date information.
- Tall Label Kit for labels up to 7 ½" tall.
- Stepper motor/drive provides finer control of label dispensing speed.
- Conveyor width: 4 ½"
- Conveyor height: 32" Standard (+2" up)
- Conveyor length: 84"
- Conveyor motor: ⅛ hp variable speed DC drive
- Overall machine width: 40"
- Overall machine height: 42"
- Overall machine weight: 350 pounds
- Power requirements: 120 volt AC, 60 cycle, 10 amp power
- Compressed air: 3-4 cfm @ 65 psi required

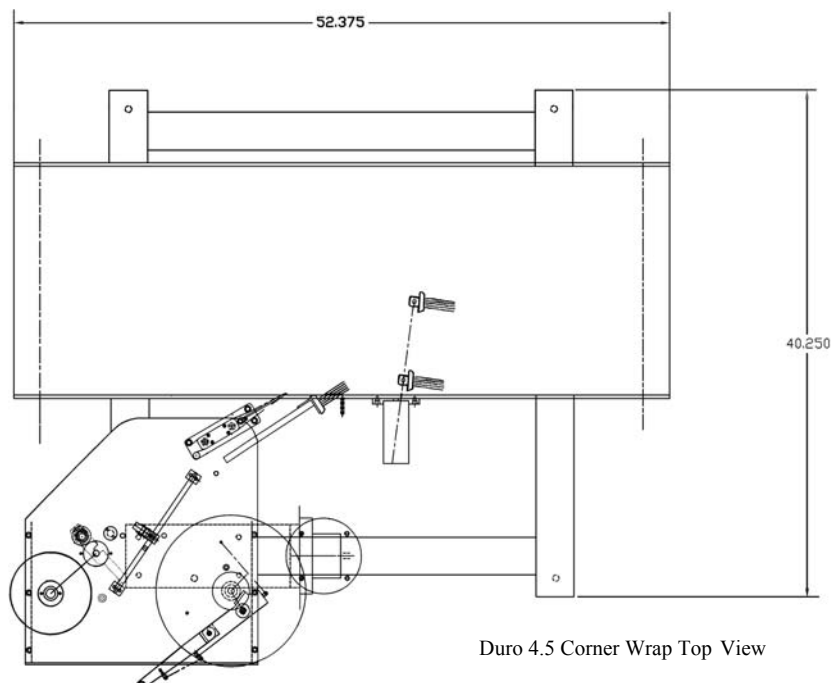

Duro 4.5 Corner Wrap Top View