



1000 Feed Screw Pressure Sensitive Labeler

Description

The model 1000 Feed Screw Labeler is a fully automatic labeler designed for high speed labeling on round bottles where precise spacing is required.

Consistent, precise label application is controlled through the use of the feed screw that orients the bottle as well as photoeye detection, photoeye gap detection and a state-of-the art PLC.

With available options, the 1000 FS can be configured to label tapered containers, gallon containers, apply label coding, or place a full wrap label on a square bottle. The inclusion of stepper or servo motors provides faster and even more accurate label application.

Versatile, easy to operate, and economical, the model 1000 provides an excellent entry level labeling solution for food and beverage, nutritional, household, and chemical packagers!



1000 FS application orienting to a thumb tab on the lid.



1000 Feed Screw Label

Specification

- Conveyor width: 4 ½"
- Conveyor height: 32" Standard (+2" up)
- Conveyor length: 108"
- Conveyor motor: ¼ hp variable speed DC drive
- Overall machine width: 42"
- Overall machine height: 42"
- Overall machine weight: 450 pounds
- Power requirements: 120 volt AC, 60 cycle, 15 amp power
- Compressed air: 3-4 cfm @ 65 psi if required

Features

- Label 1" to 6" diameter containers.
- Apply labels from 1" to 4 ½" tall and 14" long. Tall label kit option is available.
- Label can be moved up to 8" from base of container.
- Accepts random or continuous bottle feed.
- Changeovers require no tools and take less than 10 minutes.
- Feedscrew is standard with machine.
- Labeling speeds to 120 containers per minute.
- ⅛" standard label gap.
- Accepts industry standard 3" diameter core.
- Maximum label roll size of 14".
- Photoeye product detection and photoeye gap detection.
- Servo-driven label applicator with speeds to 1600 ipm.

Options

- Hot Stamp coding for lot/date information.
- Extra Tall Label Kit for labels up to 7 ½" tall.
- Taper attachment for labeling tapered containers.

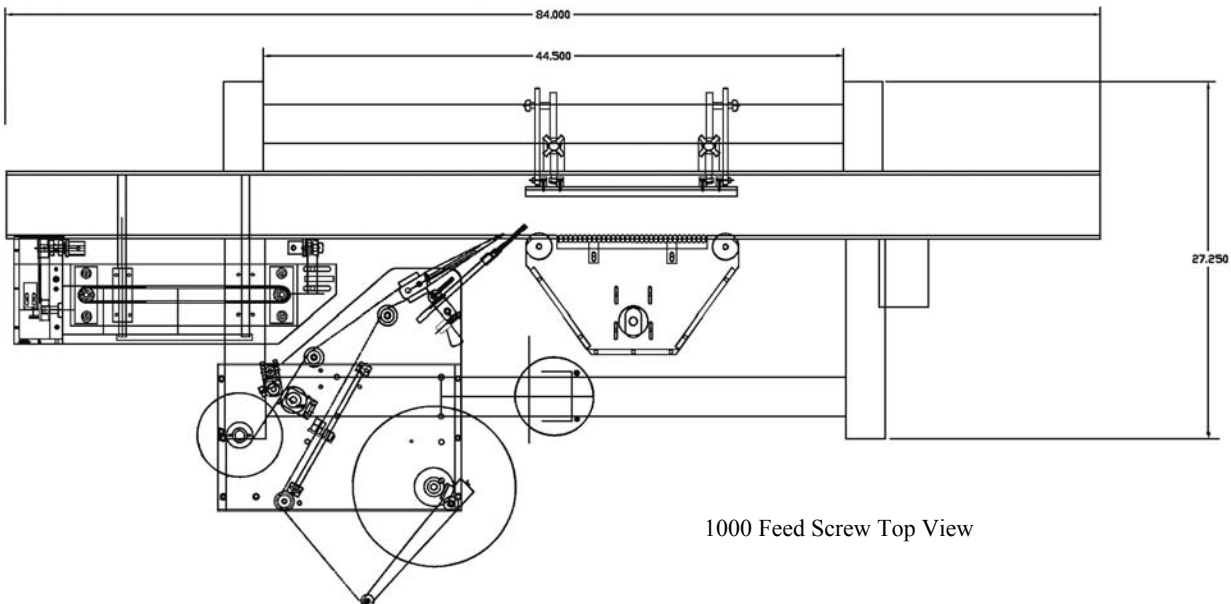

1000 Feed Screw Top View