

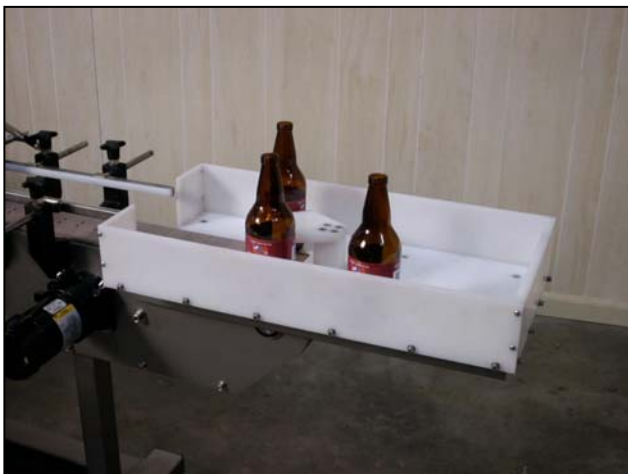

1000 Meheen Pressure Sensitive Labeler

Description

The model 1000 Meheen is a fully automatic labeler designed for the accurate placement of labels on round bottles. The Meheen 1000 has an extended conveyor that allows easy infeed of bottles from the filler. The discharge collection tray is a standard feature.



Consistent, precise label application is controlled through the use photoeye detection, photoeye gap detection, and PLC controls.

With available options, the 1000MH can be configured to label tapered containers and apply label coding. The inclusion of stepper motors provides faster and even more accurate label application.

Versatile, easy to operate, and economical, the model 1000MH provides an excellent entry level labeling solution for beverage labeling including beer. It is designed to work in tandem with the Meheen family of bottlers with 4-head standard and 6-head optional.



1000 Meheen shown with Hot Stamp Coder.

Specification

- Conveyor width: 4 ½"
- Conveyor height: 32" Standard (+2" up)
- Conveyor length: 96"
- Conveyor motor: ⅛ hp variable speed DC drive
- Overall machine width: 42"
- Overall machine height: 42"
- Overall machine weight: 350 pounds
- Power requirements: 120 volt AC, 60 cycle, 10 amp power
- Compressed air: 3-4 cfm @ 65 psi if required

Features

- Label 1" to 6" diameter containers.
- Apply labels from 1" to 4 ½" tall and 14" long.
- Label can be moved up to 8" from base of container.
- Accepts random or continuous bottle feed.
- Changeovers require no tools and take less than 10 minutes.
- Spacing Wheel standard with machine.
- Labeling speeds to 100 containers per minute.
- ⅛" standard label gap.
- Accepts industry standard 3" diameter core.
- Maximum label roll size of 12".
- Photoeye product detection and photoeye gap detection.

Options

- Hot Stamp coding for lot/date information.
- Extra Tall Label Kit for labels up to 7 ½" tall.
- Auto-Set Feature for automatic bottle/label setup.
- Taper attachment for labeling tapered containers.
- Stepper motor/drive for finer labeling control.
- Blow-off module for condensate.

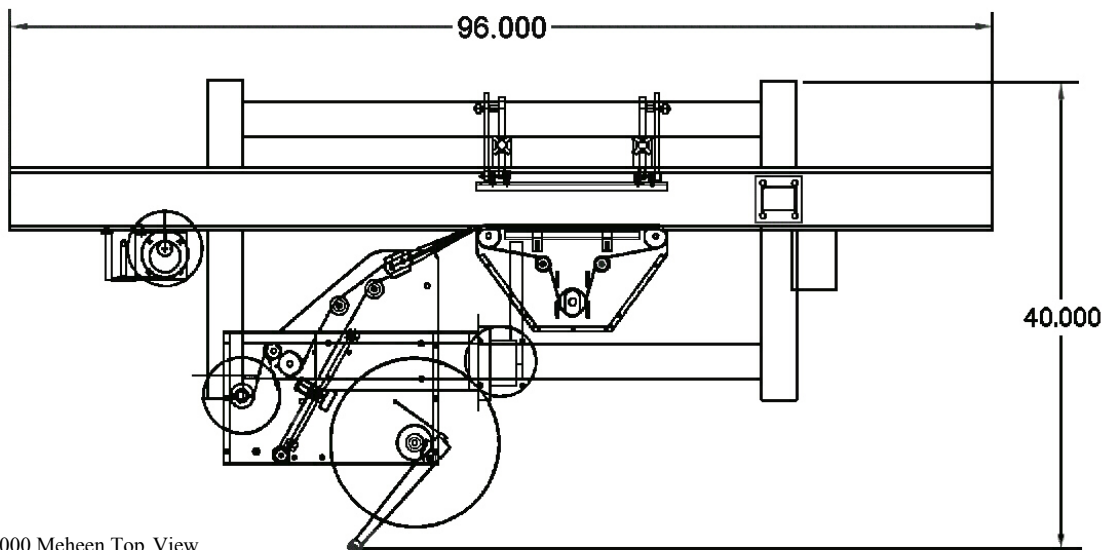

1000 Meheen Top View