

Semi-Automatic shown with Hot Stamp Coder

Semi-Automatic Pressure Sensitive Labeler

Description

The Semi-Automatic Pressure Sensitive Labeler makes it possible for every company to enjoy the benefits and accuracy of mechanically applied labels.

The Semi-Automatic Pressure Sensitive Labeler is capable of applying

labels up to 5 ½" tall on round bottles from 1" to 4 ½" in diameter. It is capable of applying labels up to 10" in length.

With separate motors and a label gap sensor included, the Semi-Automatic operates on its own; starting and stopping the bottle and label feed automatically. A convenient foot switch provides "hands-free" labeling.

The accuracy and consistency of the label application of the Semi-Automatic is virtually indistinguishable from that done on a fully automatic machine. The Semi-Automatic is a quality labeler priced to fit any budget.



Features

- Accepts round bottles from 1" to 4½" in diameter and labels sizes from 1" to 5 ½" tall and 10 " in length.
- Adjustments for label height on bottle.
- Changeovers require no tools and take less than 10 minutes.
- Accepts an 8" label reels with the standard 3" core.
- Adjustable top pressure roll.
- "Hands-free" operation for greater labeling speed.

Options

- Hot Stamp coding for lot/date information.
- Two-label feature allows machine to apply two labels to the same round bottle (front/back) when the labels are alternating on the same web.
- Take-up reel for spent web.

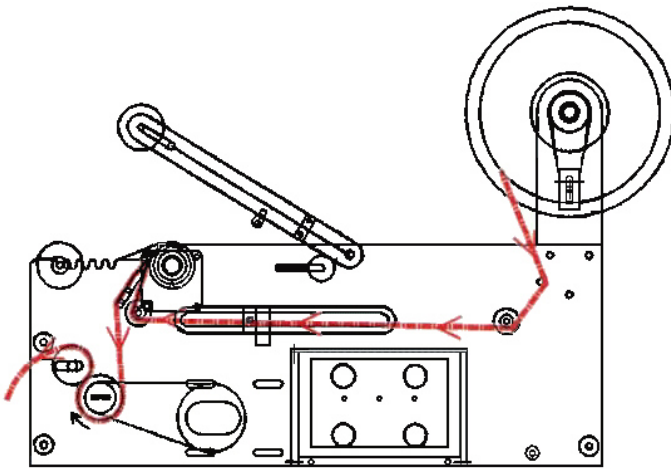

WebMaster Semi-Automatic web path

Specification

- Machine width: 10½"
- Machine height: 18"
- Machine length: 22"
- Machine weight: 40 pounds
- Labeling Head Motor: ⅛ hp variable speed DC drive
- Power requirements: 120 volt AC, 60 cycle, 5 amp power
- Compressed air: 3-4 cfm @ 65 psi if required

