

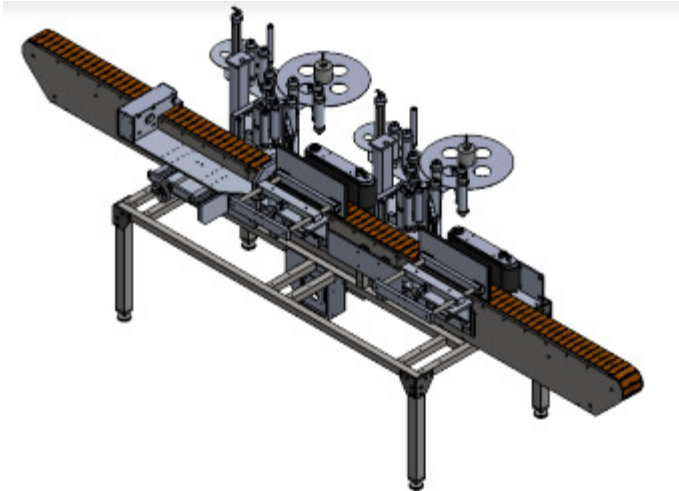

## Model 1000 SS Labeler

The Model 1000 SS is a fully automatic labeler especially designed for speed and zero downtime. This machine can consistently apply to your round containers. Redundant heads allow for label change without machine stoppage especially convenient in high speed environments and food packaging. Standard features on the Model 1000 SS include single feedscrew infeed, redundant applicator heads, and an ultra-fast PLC and accurate stepper-driven labeling applicators (servo-driven if high speed).



### Machine capabilities:

- Speeds to 70 bpm stock depending on label length. Up to 200 bpm with dual servos.
- Fully automated
  - PLC controlled
- 1" to 6" tall x 14" long labels
  - Upgradable to 7 1/2" tall labels
- Consistent pressure across the entire label length
- Fully adjustable from 1" to 5" diameter containers
- Changeovers require no tools and take less than 10 minutes.

## Options

7-1/2" Tall Label Upgrade  
Single Servo Upgrade (120 cpm)  
Dual Servo Upgrade (180-200 cpm)  
Extended Conveyor Upgrade

## Contact us

Phone: [843-569-2530]

Email: [sales@inlinepack.com]

Web: [inlinepack.com]

